

Freedom 21 – Modifications to Twin Lift Keel System



The twin lift keel modification to the Freedom 21 was installed on boats manufactured in the UK during the period 1984 - 89 and gave the boat a draft of 0.76m (2ft 6") keels down and 0.4m (1ft 4") keels up. However this ingenious twin keel lifting system has a number of inherent design problems that need to be addressed in order to make it a more practical and seaworthy arrangement and this article describes the modifications I made to my Freedom 21 DAYDREAM.

The lifting keels weigh about 260lb each and consist of a mild steel plate with a bolted-on cast iron, winged-keel bulb at the tip of the plate. The keels slot into fibreglass keel boxes which are moulded into the two raised table sections each side of the cabin between the main cabin bunks and the forward bulkhead. These keel boxes are canted outwards slightly and each keel box carries two stainless steel guide plates which fit each side of the keel plate and restricts keel plate movement by guiding a stainless steel pin, which is fitted to each of the keel plates and engages in a longitudinal slot in the guide plates – see **Figure 1**. These plates also act as a "stop" mechanism for the keels.

The keels are raised by a lifting line which is attached to the top of the keel and passes over a ball-race pulley fitted to the top of the keel box. This line passes up an aluminium alloy tube connecting the top of the keel box to the cabin roof, and then round a turning block fitted on top of the cabin roof and aft via a multi-block tackle system to the jamber clutches on each side of the sliding hatch. To lift the keels it is necessary to use the winches in conjunction with the jamber clutches, since even with low-friction pulleys in the system the loads are significant.

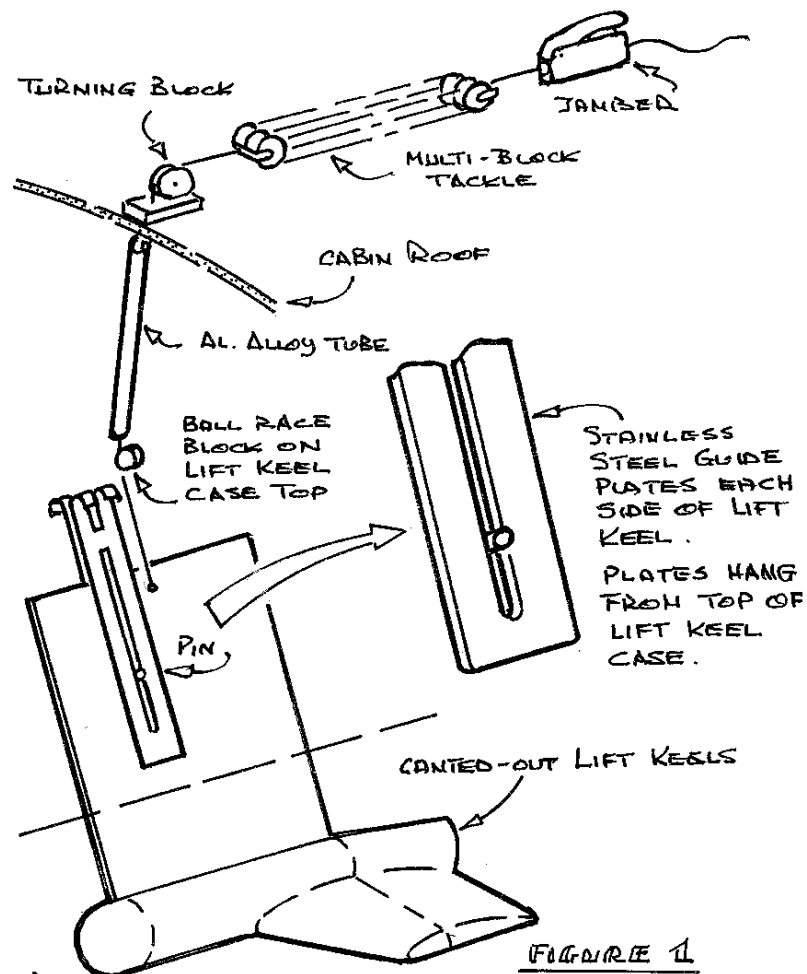

When I purchased my boat the surveyor noted that the turning blocks on the cabin roof were in a very poor condition and seemed to be inadequate for the loads involved, since on one of the blocks the thin stainless steel housing had buckled and the plain-bearing sheave had completely broken-up. Also the hardwood pads supporting the turning blocks had badly deteriorated.



fitted inside the fibreglass cover and the whole assembly is coated with a silicone sealer and assembled under load so that the wooden wedges slide over each other to form a solid packer when the silicone sealer has fully cured. Whilst the overall keel lifting concept is fine, this particular design has some fundamental practical problems that demand more suitable solutions, namely:

- *The hardwood pads under the cabin roof turning blocks were breaking-up & splitting under load.*
- *The cabin roof turning block units were buckling and the sheaves were breaking-up under load.*
- *Rainwater was entering the cabin through the aluminium tube where it connects to the turning block unit.*
- *It was impossible to examine the lifting-line connection to the top of the lifting keels and replace these without dismantling the whole assembly and dropping the keels out of the bottom of the boat.*
- *The lifting-line attachment to the lifting keel was not considered to be a secure arrangement.*
- *To remove the cabin roof liner the complete cabin roof turning block assembly had to be removed and the compression tube withdrawn.*
- *It was not possible to lift the “glued-in-place” fibreglass covers to examine the top of the keel box.*

Cabin Roof Turning Block Problems: I made-up heavy-duty stainless steel welded mountings for the sheaves and installed 50mm (2”) dia. High-performance HARKEN 311 ball-race sheaves with a 2000lb safe working load. I replaced the hardwood pads supporting the turning block units with phenolic/cotton laminate (TUFNOL) to eliminate the weathering and deterioration problems associated with hardwood. And to avoid problems where the compression tube protrudes through the cabin roof moulding and bears on the underside of the TUFNOL block I fitted a thin stainless steel plate to handle these local bearing loads.



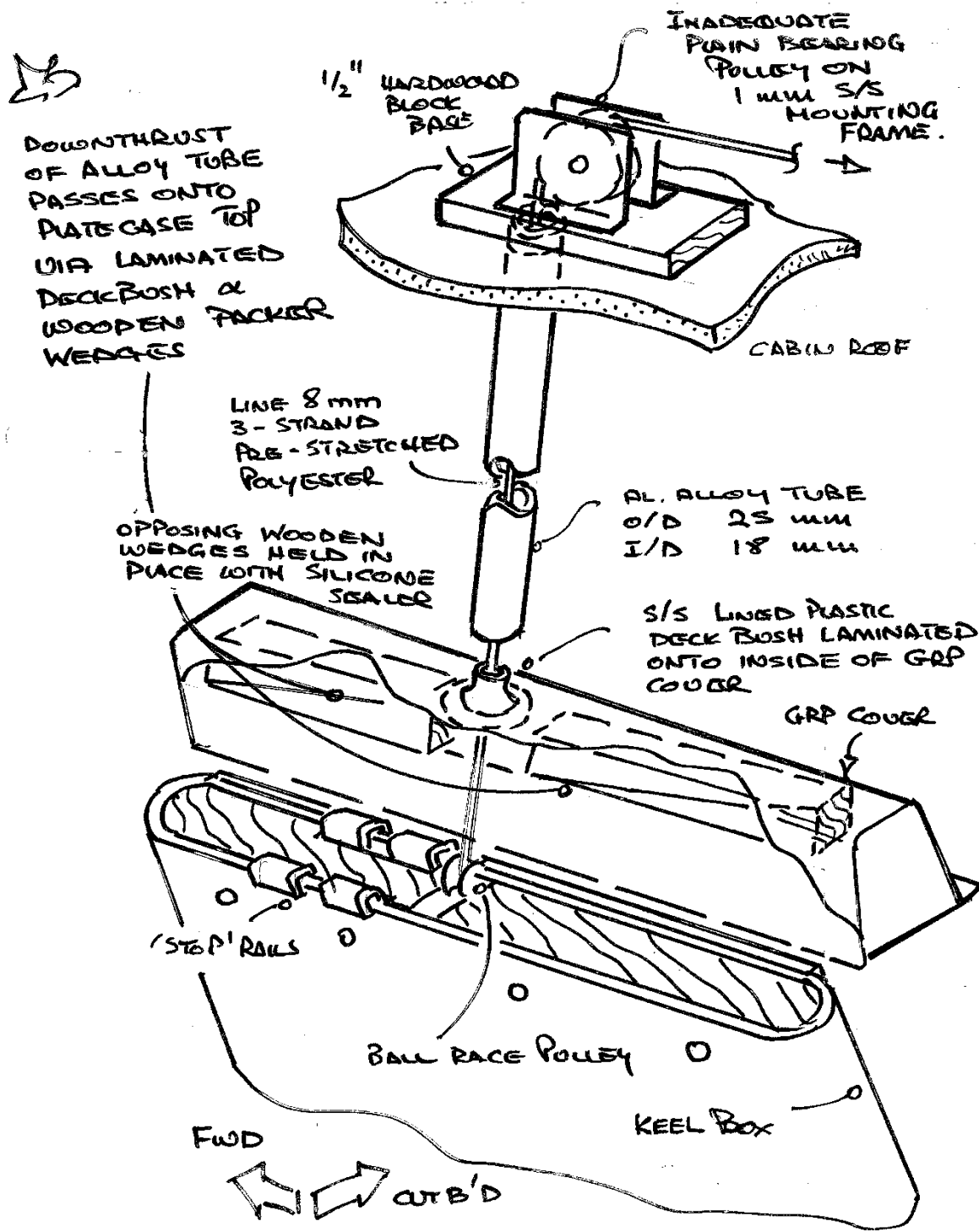
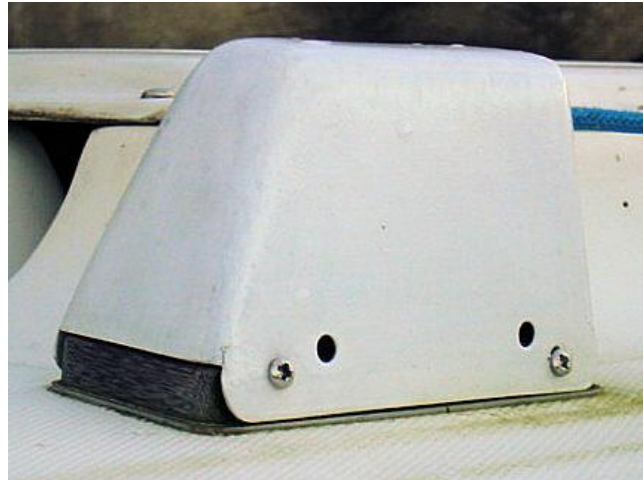

FIGURE 2

Rainwater Penetration Problem: To prevent the entry of rainwater into the cabin I made-up a pair of glass fibre/epoxy covers that are fitted over the turning block units and attached to the TUFNOL base pad with stainless steel self-tapping screws and silicone sealant. Note that drainage holes have been provided to prevent any build-up of water in the covers. Details of how these units were made are given in an article I published on the F21 site.



Lifting Line Attachment Problem: When the lifting keel units were removed it was evident that the method of lifting line attachment was really inadequate as it involved only a lightweight stainless



steel strap and a small diameter clevis pin attached with a stainless steel wire ring. It seemed likely that the stainless steel wire ring could fail and the stainless steel strap could then distort and disengage from the clevis pin, leaving only the guide plate system to prevent the keel from falling out of the keel box. The system used to replace this arrangement is shown in concept form in **Figure 3**.

In this design the lifting line locates over pin **B** which is integral with plate **A** that is welded to the keel plate. A removable plate **C** is then fitted to prevent the lifting line coming off the pin. The whole assembly is locked in position with a stainless steel "R" clip.

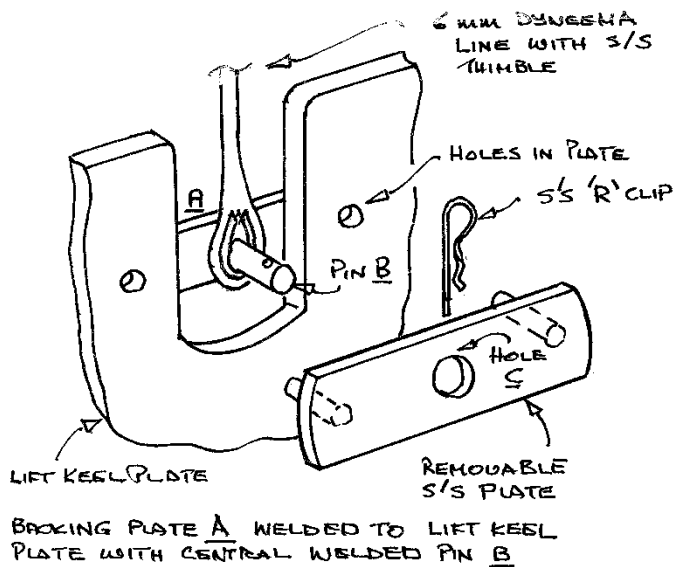
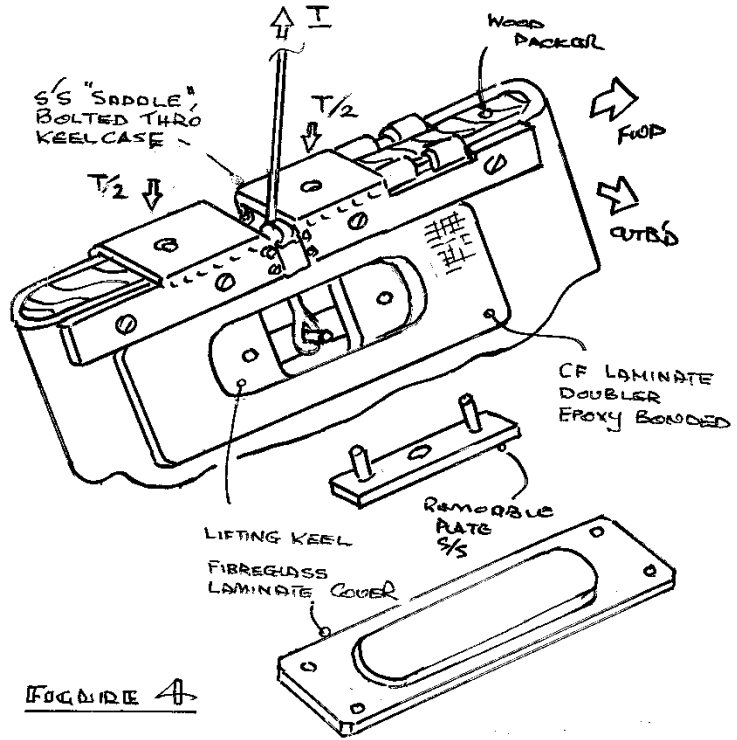

FIGURE 3

The key "fail-safe" feature of this design is that even if the "R" clip is removed, plate **C** cannot disengage from the lifting keel, since it has two long retaining pins, which pass completely through the keel plate, so that the removable plate cannot physically disengage from the keel plate – there is just not enough space within the keel box to allow this. Plate **C** can only be removed when the lifting keel is fully raised and supported and a hatch is opened in the side of the keel box to gain access. This design enables one to gain access to the lifting line fixing point and replace a worn line without dismantling the whole assembly and without dropping the keels out of the boat.

Lifting Line Replacement Problem: The solution to this problem was to cut a hatch in the outboard, upper side of each keel box and reinforce this cut-out with an epoxy bonded CF laminate doubler – **Figure 4.** This hatch allows clear access to the lifting line attachment point when the keels are raised and supported, as would occur when the boat “dries out” with keels raised or is on its road trailer. The hatch is closed with a fibre glass laminate cover that has a doubler region that corresponds to the cut-out zone and restores the inner face of the keel case when the cover is bolted in place. The cover is bolted in place with stainless steel set-screws that locate in stainless steel tapped plates laminated into the CF laminate doubler. When the cover is bolted in place a smear of grease on all mating faces creates a watertight seal.



The tension in the lifting line **I** is reacted by the compression tube linking the keel box to the cabin roof moulding and the load passes down into the keel box through the stainless steel “saddle” unit that is bolted through the top of the keel box and the wooden packers inside the top of the keel box. This arrangement makes replacement of the lifting line a simple operation.



Replacement of Lifting Line: The lifting lines can be easily replaced when the keels are raised and supported as follows – see **Figure 5**:

1. *The lifting line is slackened-off and disconnected from the multi-part tackle on the cabin roof.*
2. *The fibreglass cover is removed from the turning block on the cabin roof.*
3. *The stainless steel tube is unbolted from “saddle” capping-plate and can then slide-off the “saddle” capping-plate and be disengaged from the socket hole in the roof of the cabin.*
4. *The end of the lifting line is passed down through the cabin roof and through the stainless steel tube.*
5. *The keel box cover is removed, the “R” clip is withdrawn and the removable plate disengaged to allow the lifting line to be removed.*
6. *The replacement lifting line is fitted and the above procedure is reversed – it is helpful to use a thin cord feeder line to pull the lifting line back up the stainless steel tube and through the turning block assembly.*

In this revised design the cosmetic fibre glass cover for the top of the keel box takes none of the compression load in the stainless steel tube and this load is distributed directly into the keel case through the stainless steel “saddle” capping-plate which is securely through-bolted to the top of the keel box. The 5mm (0.2”) thick carbon fibre doubler reinforcement around the cut-out in the keel box is more than adequate to carry the compression loads around the cut-out and into the keel box.

When unbolted from the “saddle” capping-plate the stainless steel compression tube easily slides-out and can be disconnected from the lifting line. The replacement of the small diameter aluminium alloy tube with a large diameter (38mm – 1.5”) stainless steel tube allows the end spliced eyes of the lifting line to pass through the tube with no problems. Also the larger diameter hole in the turning block base allows the lifting line eyes to pass through this unit easily.

The ease of removal of these compression tube members makes it a simple operation to remove the cabin ceiling panels and gain access to the cabin roof for routine maintenance of any through-bolted deck fittings.

Summary: This revised design is a significant improvement of the lifting keel mechanism in terms of simplicity, structural strength, reliability and access and although my marine surveyor commented that this is something of an expensive “Rolls-Royce” solution, I feel that this cost is justified when one considers the difficulty and hazard that could arise if one “lost” one of the lift keels when at sea. This is not an unrealistic scenario, since I have met an owner of a twin lift keel Freedom 21 who lost one of the keels when the lift line broke and the keel disengaged from the keel box guide plates in very rough conditions in the North Sea. The Freedom 21 lifting keel concept is a sound one, but regular routine maintenance is essential and my improved design enables this maintenance to be an easy task.

Wilf Bishop
15th October 2009

FIGURE 5

